

WESPAC X

Development of Real System in Near 3D Sound Field Reproduction System Using Directional Loudspeakers and Wave Field Synthesis

T. Kimura¹, Y. Yamakata¹, M. Katsumoto¹,
T. Okamoto², S. Yairi³, Y. Iwaya², and Y. Suzuki²

¹NICT, Japan

²Tohoku University, Japan

³Miyagi National College of Technology, Japan

Introduction

- Ultra-realistic communication system
 - 3D video and audio pop up in a 3D space
 - Several people can view the object anywhere in its vicinity without having to wear equipment such as glasses



3D Audio Display System

- Compatible with the 3D visual display systems
 - Several listeners can listen to an object's sound anywhere in its vicinity without having to wear equipment such as headphones

Original Sound Field

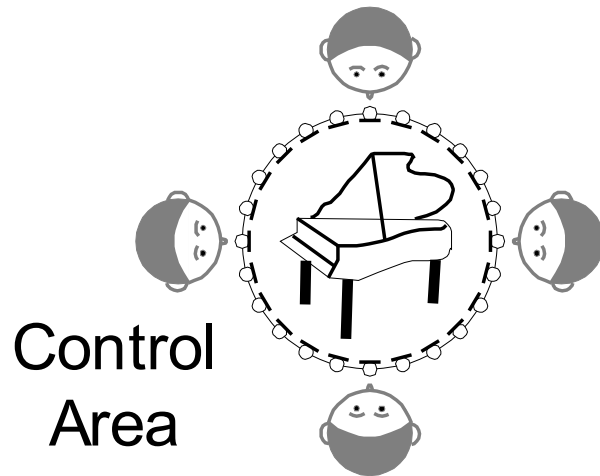

Reproduced Sound Field

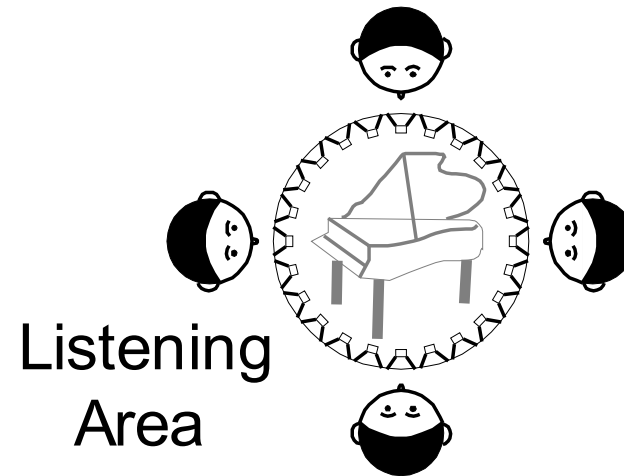

Aim of This Talk

- We have proposed the 3D audio display system using directional loudspeakers and wave field synthesis
 - Last year...ACOUSTICS'08 (in Paris)
- We developed the real system and generated the string quartet sound
 - Surrounding microphone array
 - Radiated loudspeaker array
- The developed system is displayed at an exhibition

Diagram of Proposed Systems

1. In the original sound field, the surrounding microphone array is placed and audio signals, $x_i(t)$, are recorded

Original Sound Field

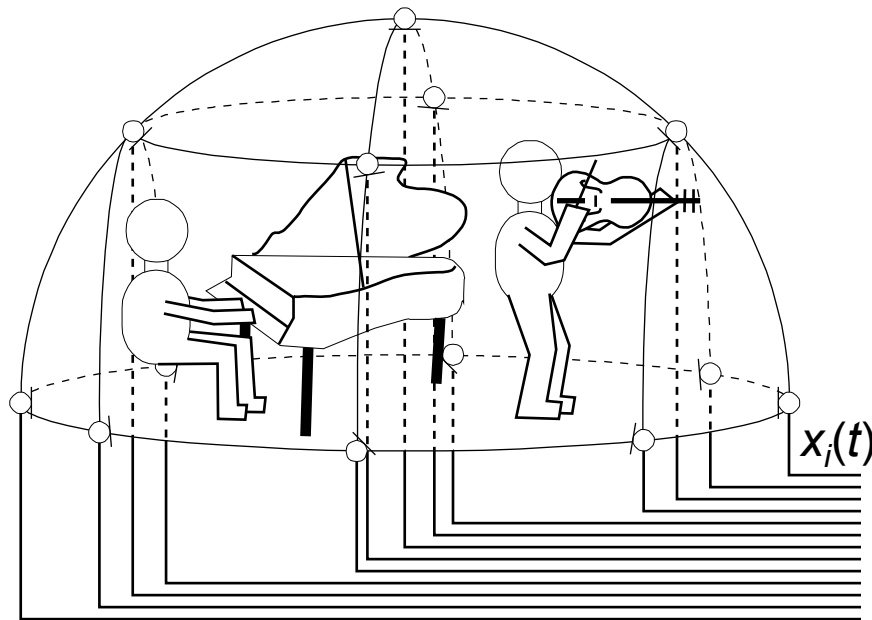

Diagram of Proposed Systems

2. In the reproduced sound field, the radiated loudspeaker array is placed and the recorded audio signals, $x_i(t)$, are directly replayed

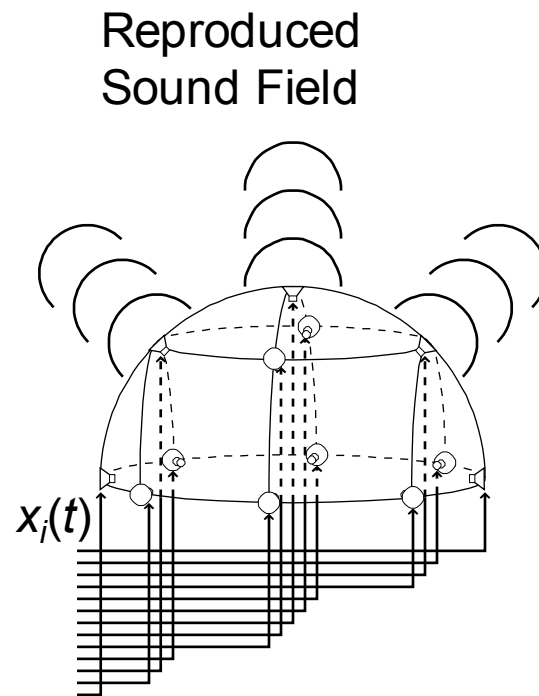

Diagram of Proposed Systems

3. A sound field is generated on the outside of the radiated loudspeaker array according to Huygens' principle

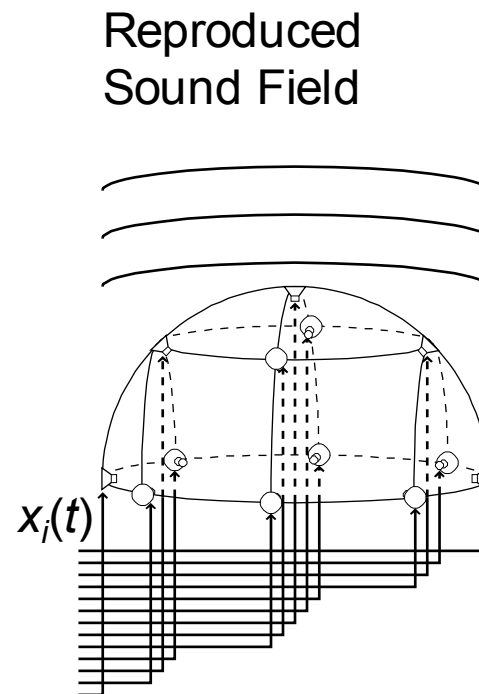

Diagram of Proposed Systems

4. If the shape of the loudspeaker array is similar to that of the microphone array, the generated sound field will be similar to that of the musical players

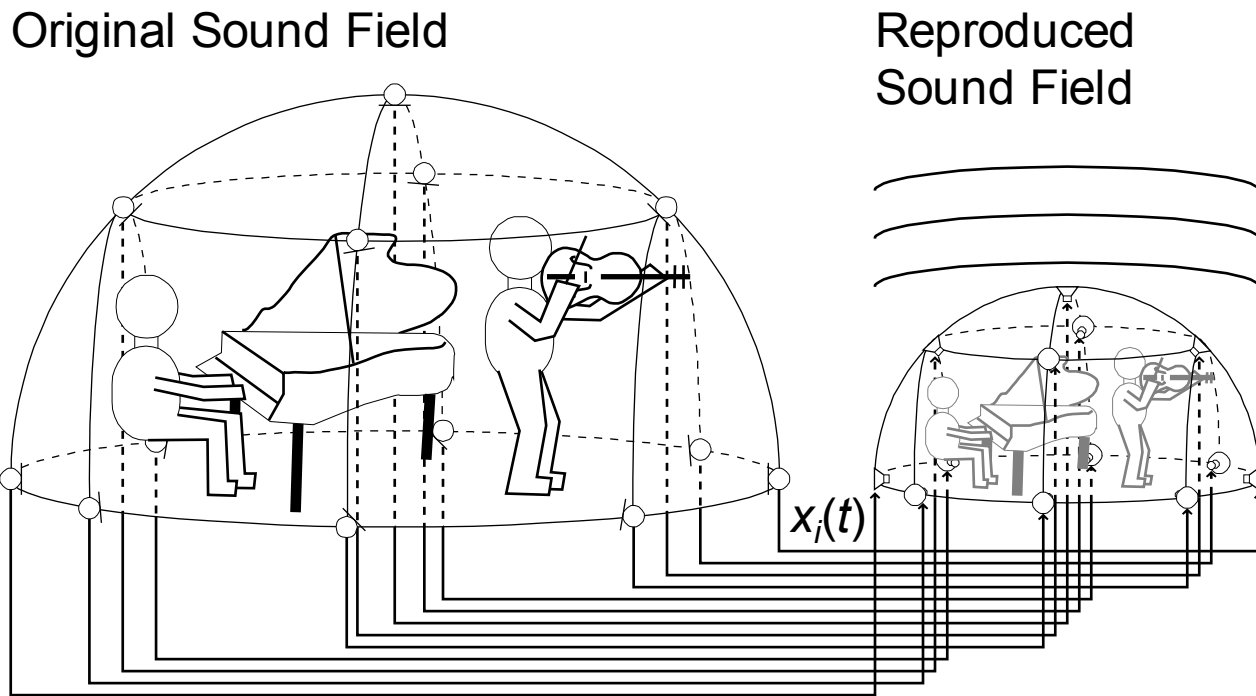
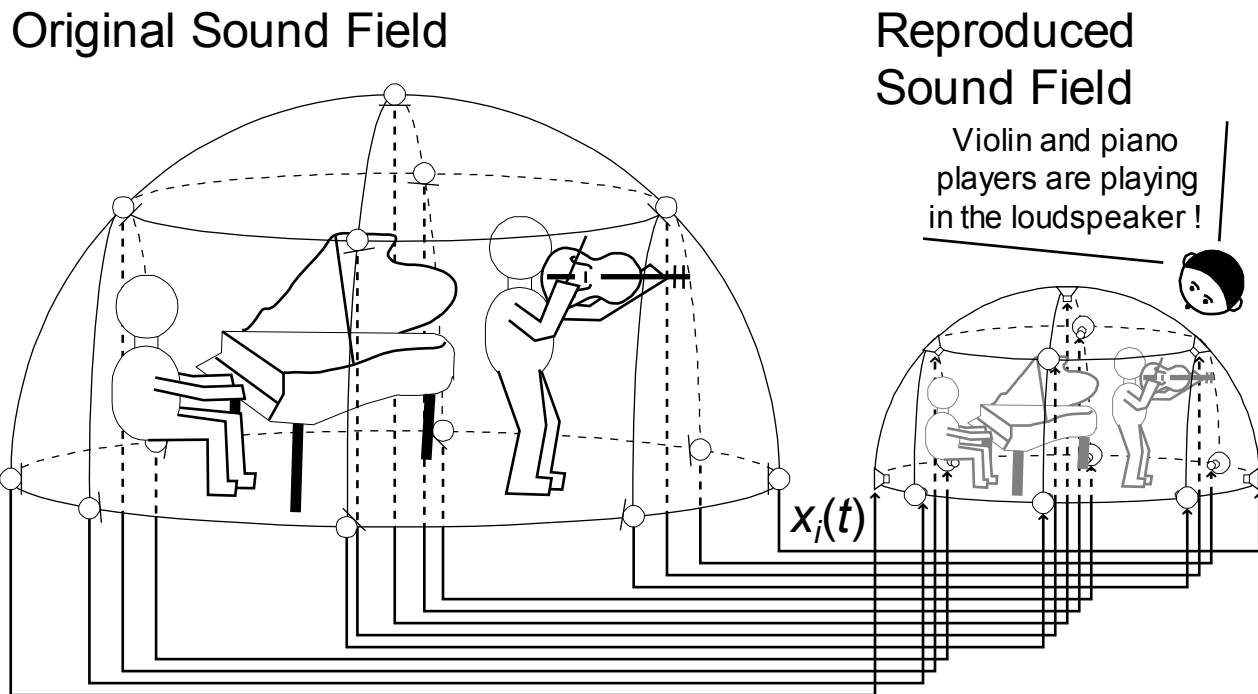

Diagram of Proposed Systems

5. Several listeners on the outside of the radiated loudspeaker array feel as if they can listen to the sound at any position around the musical players



Surrounding Microphone Array

- Surrounding microphone array room
 - Equipped in RIEC, Tohoku Univ.
- 157 omnidirectional microphones
 - Brüel & Kjær: Type 4951
 - Placed on 5 planes
 - Record the direct sound from sound sources placed in the room
- Reverberation time
 - About 150 ms



Arrangement of Microphones

- Wall A
 - 2 planes
 - 20 (=5×4)
- Wall B
 - 2 planes
 - 36 (=9×4)
- Ceiling
 - 1 plane
 - 45 (=9×5)
- Interval...0.5 m

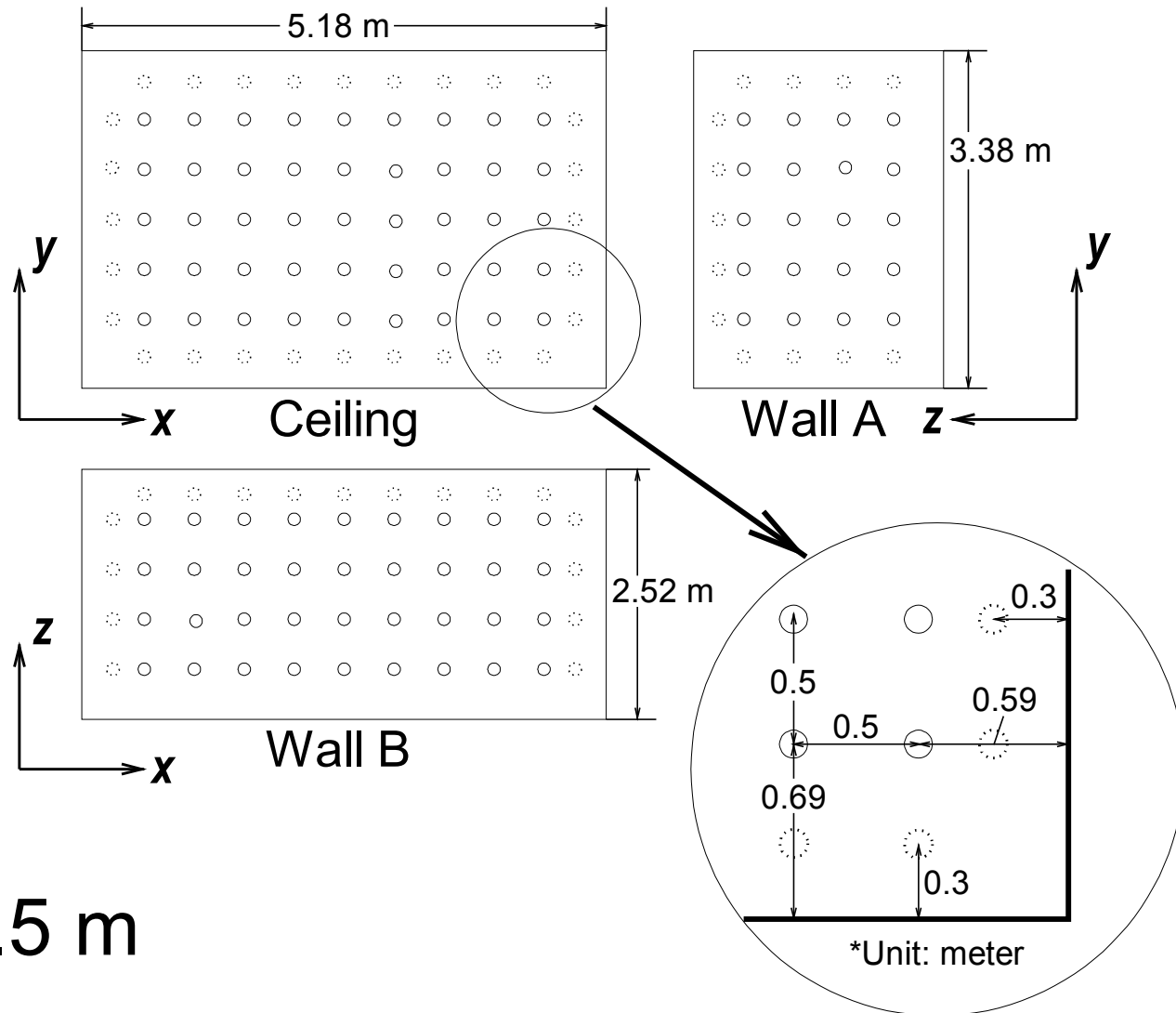

Radiated Loudspeaker Array

- Rectangular enclosure
 - Size...1/4 of surrounding microphone array
 - Material...Plywood and aluminum panels
- 157 loudspeaker units
 - AURASOUND:
 - NSW1-205-8A suitable
 - Attached to 5 planes
 - Size...1 inch
 - Directivity
 - Towards outside
- Elevated by 0.7 m



Arrangement of Loudspeaker Units

- Interval...0.125 m
- Wall A
 - 2 planes
 - 20 (=5×4)
- Wall B
 - 2 planes
 - 36 (=9×4)
- Ceiling
 - 1 plane
 - 45 (=9×5)

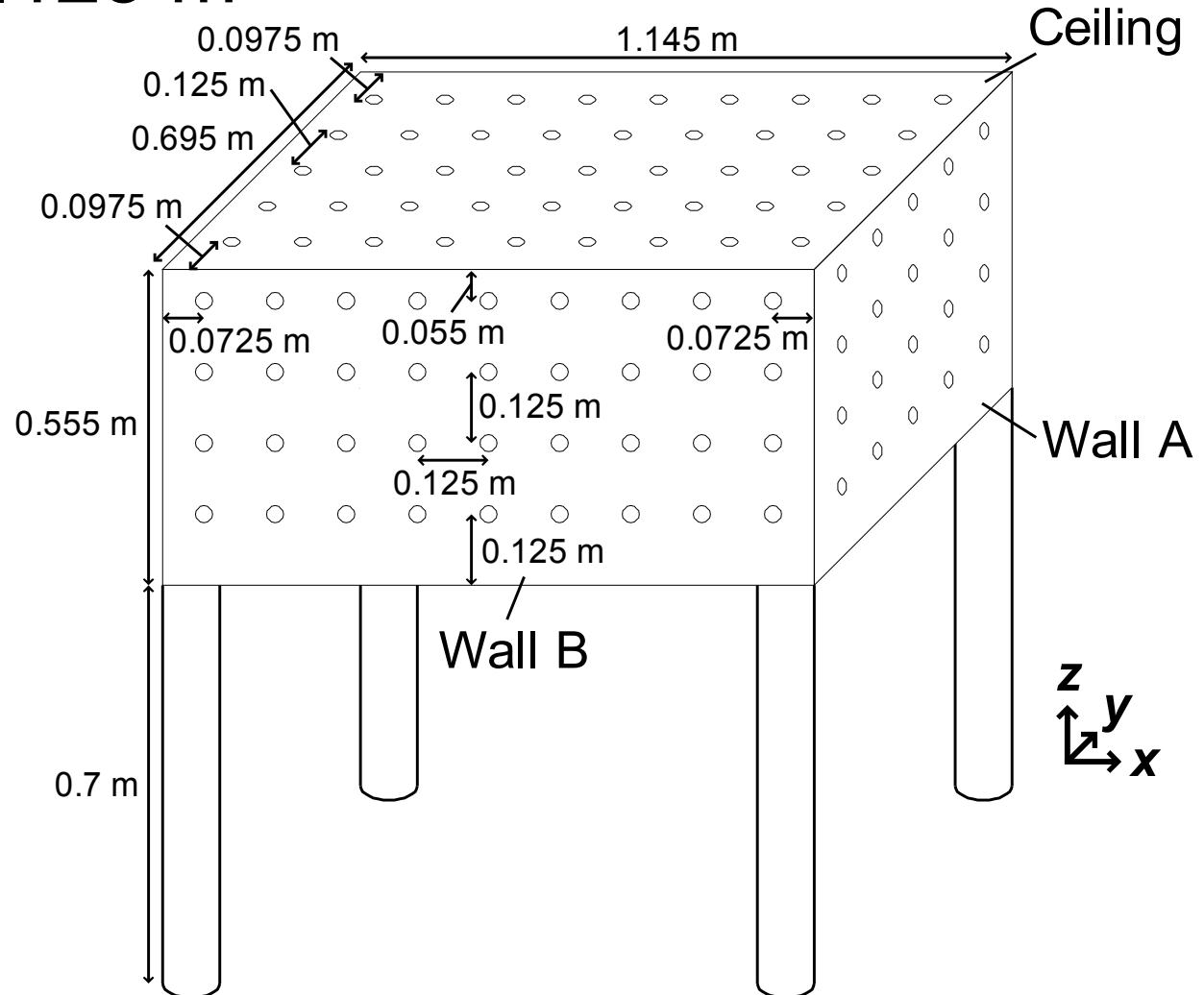

Recording of String Quartet

- The 157-ch audio signals were recorded
 - First movement of Mozart's thirteenth serenade "Eine kleine Nachtmusik"

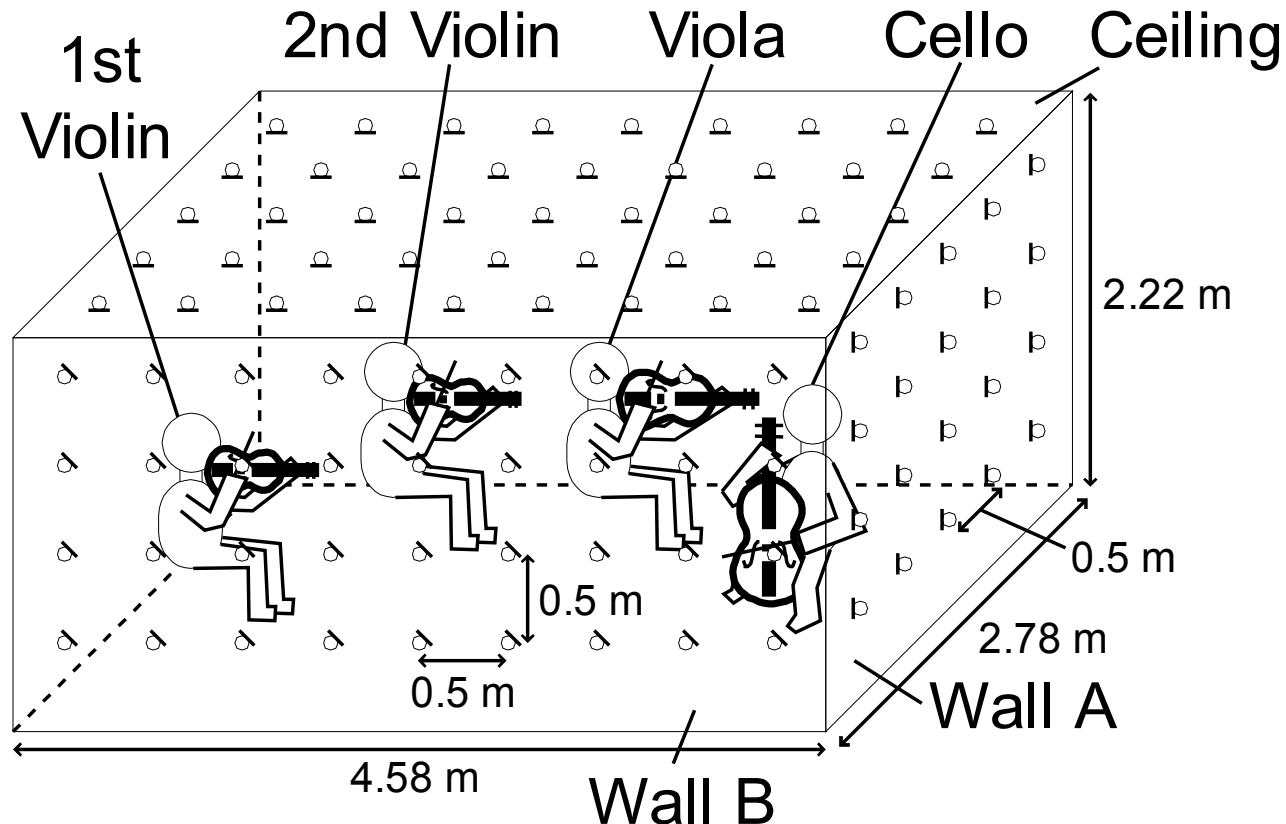

Recording Equipment

- 10 microphone pre-amplifiers (16 ch)
 - Brüel & Kjær: Type 2694
- 14 audio devices
 - Mark Of The Unicorn: HD192
- 4 recording softwares
 - Steinberg: Nuendo 3
 - Installed on four PCs
 - Apple: Power Mac G5
- Recording format
 - Sampling frequency...48 kHz
 - Quantization bit...16 bits

Playing Equipment

- The recorded 157-ch audio signals were directly replayed
- 157-ch preamplifiers
 - Custom-made
- Playing device & software
 - Digidesign: Pro Tools HD
 - Installed on a PC
 - Apple: Mac Pro
- Playing format
 - Sampling frequency...48 kHz
 - Quantization bit...16 bits

Playing of 157-ch Audio Signals

- 3D sound field was generated
 - Several listeners felt as if they could listen to the sound at any position around the string quartet

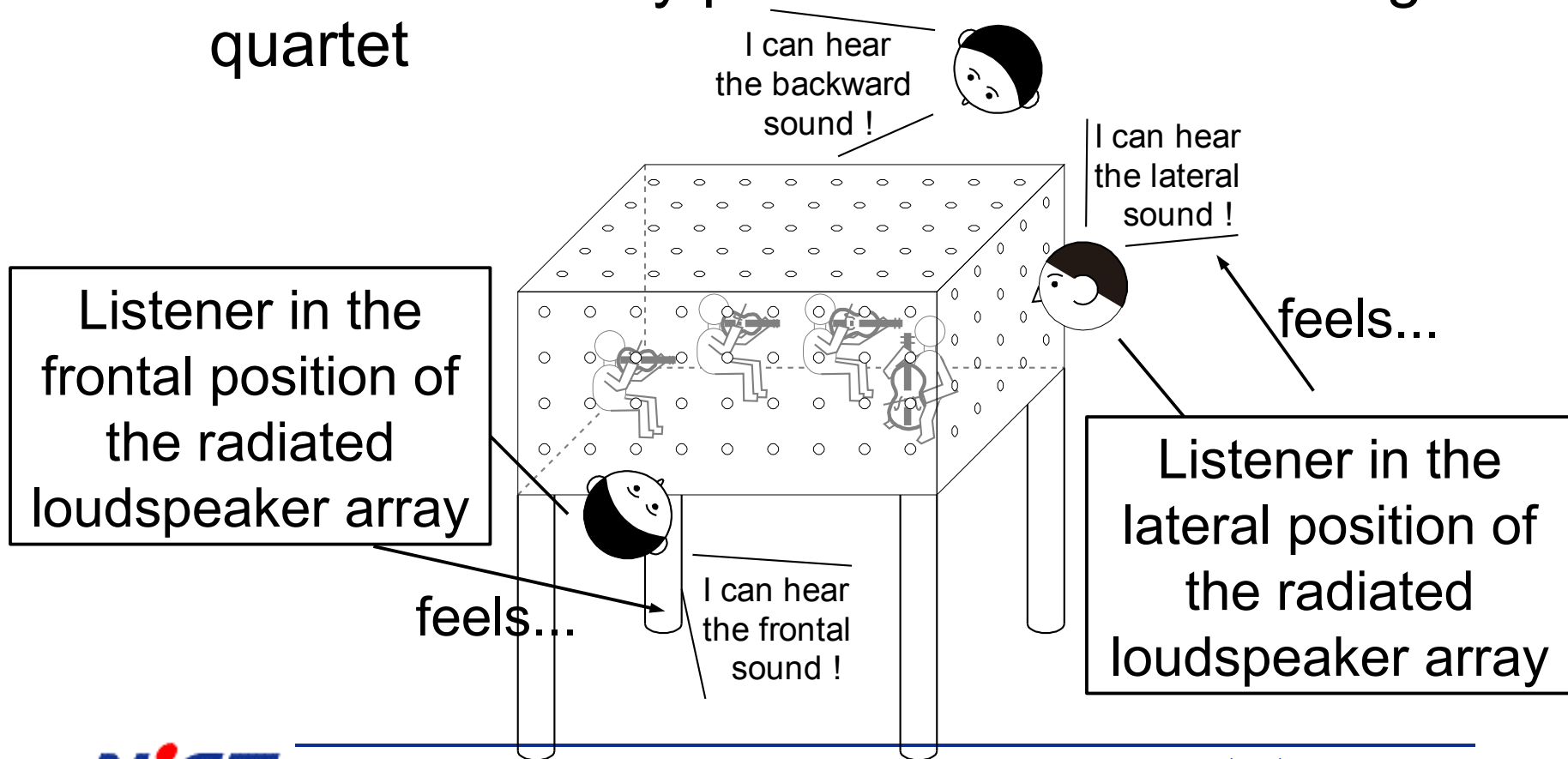

Display of Developed System

- CEATEC JAPAN 2008
 - Date
 - 2008/9/30-2008/10/4
 - Place
 - Makuhari Messe
 - Visitor
 - About several tens of thousands
 - Impression
 - Most of visitors felt that there were four musical players and the string quartet was played in the radiated loudspeaker array

Conclusion

- We developed the near 3D sound field reproduction system using directional loudspeakers and wave field synthesis
 - Surrounding microphone array
 - Radiated loudspeaker array
 - 157 microphones and loudspeakers are used
- We generated the string quartet sound and displayed at the exhibition
- Future work
 - It needs to evaluate the performance of the developed system