

Effect of the Number of Loudspeakers on Sense of Presence in 3D Audio System Based on Multiple Vertical Panning

Toshiyuki Kimura and Hiroshi Ando (NICT)

1. INTRODUCTION

Multi-view 3D video display system

- Projector array makes parallax videos
- Several viewers can view natural 3D objects without special glasses

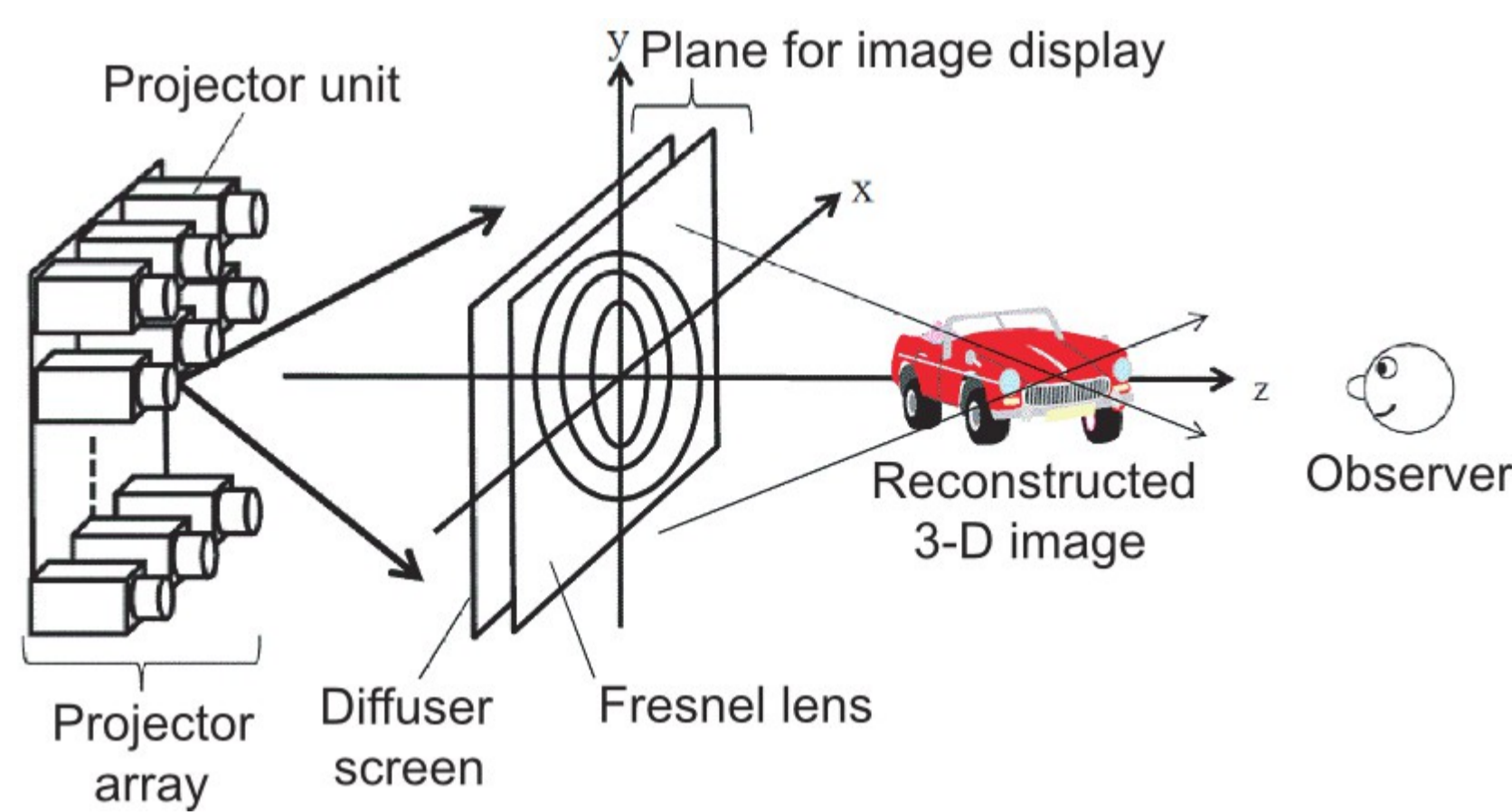

Multiple vertical panning (MVP) method

- Multiple "vertically panned loudspeakers" are placed at the upper and lower sides of the screen
- + 2 loudspeakers are placed at upper and lower sides of sound image positions
- Sound is played by the "vertical panning"
- + Viewers perceive a sound image between vertically panned loudspeakers
- + Multiple viewers can simultaneously feel the sound images at the position of the 3D objects regardless of the viewing position

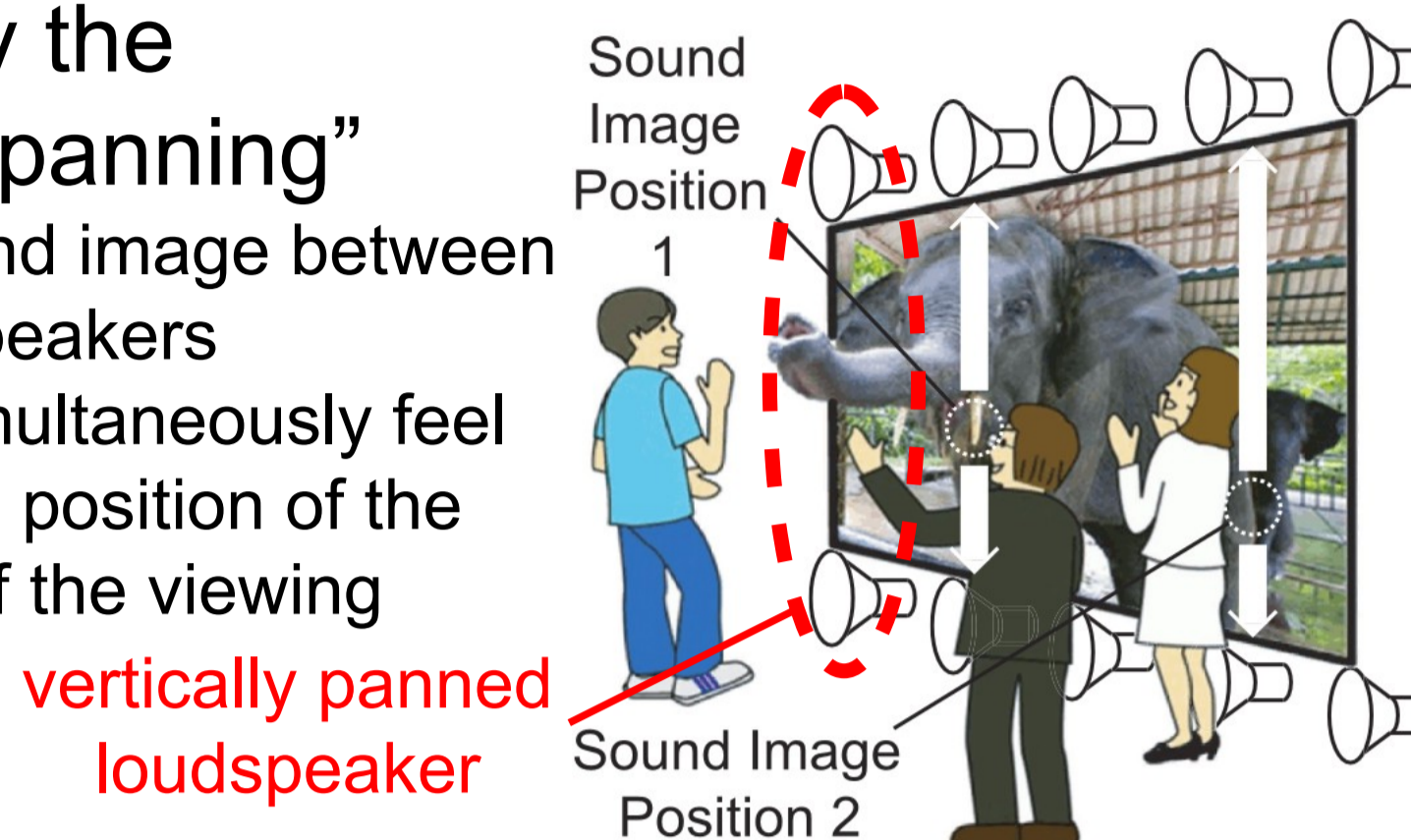

Aim of Study

- MVP method
- + Loudspeakers are densely placed horizontally to the screen
- + The number of loudspeakers is enormous
- + The number of loudspeakers must be reduced before practical realization

The effect of the number of loudspeakers is evaluated by audio-visual experiment

2. AUDIO-VISUAL EXPERIMENT

Experimental Environment

- Conference room
- + Reverberation time: 402 ms
- + Background noise level: 38 dBA
- + Viewing position: 4 positions
- + Central position (5.5 m distance)
- + Forward position (3.5 m distance)
- + Backward position (7.5 m distance)
- + Lateral position (5.5 m distance)
- + Lateral distance: 2 m (Left)
- + 42 Loudspeakers
- + 21 at upper side
- + 21 at lower side
- + Sound pressure level: about 70 dBA
- + At the central viewing position

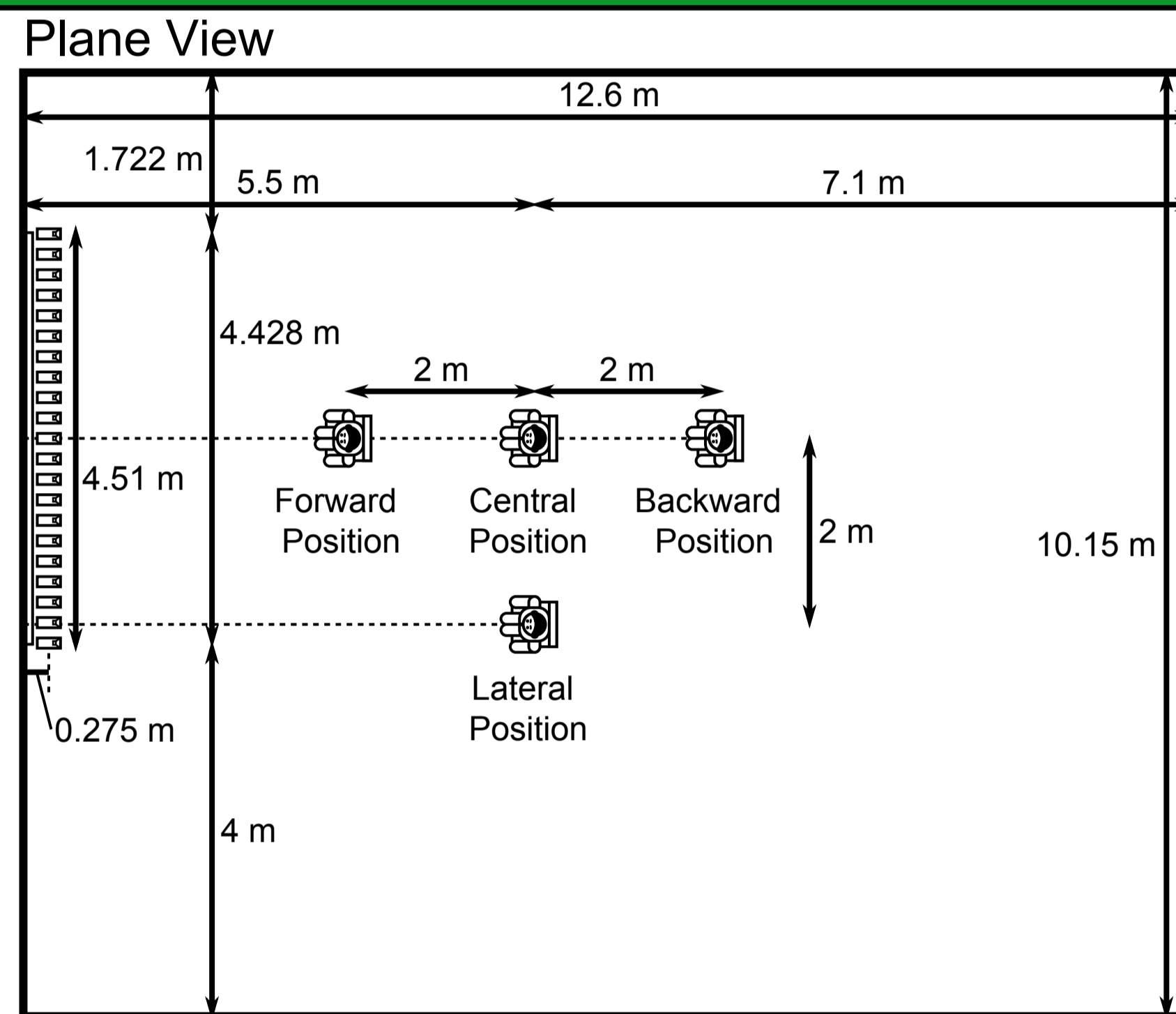

Experimental Condition

- 3D video (5 seconds)
- + UFO that plays a sound is moving about the screen (Yellow oval)
- + The sound of stars and balls is played at their position when UFO touches them (Red circles)

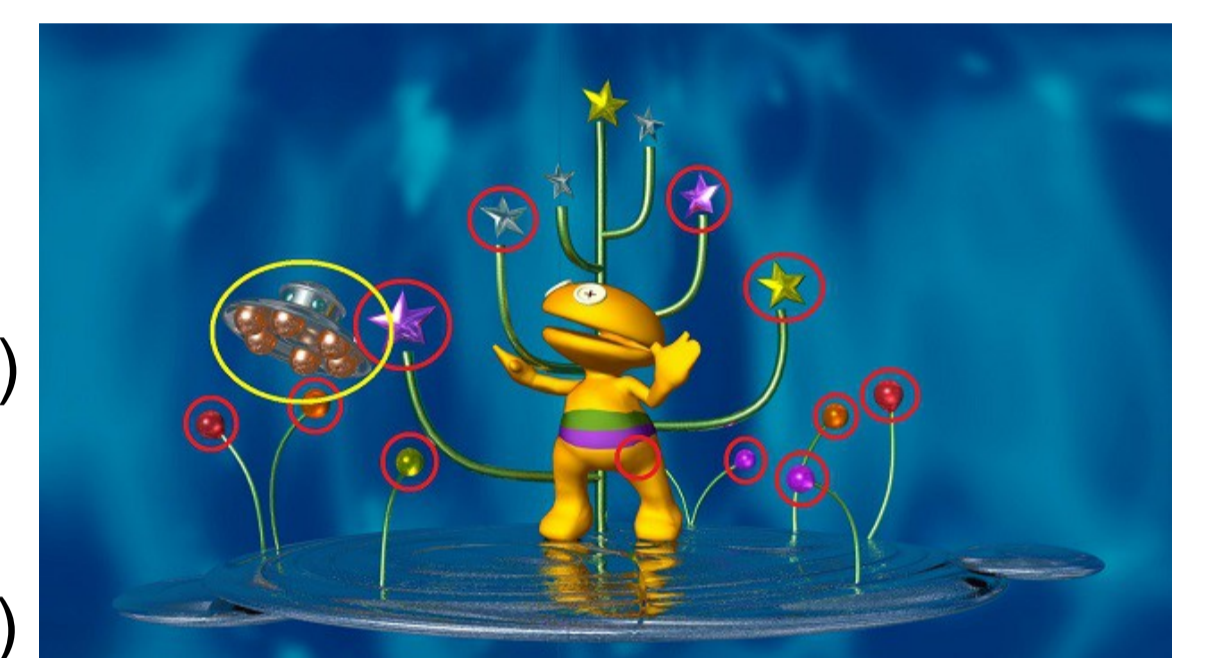

Sound condition

- + The number of playing loudspeakers varies according to sound conditions

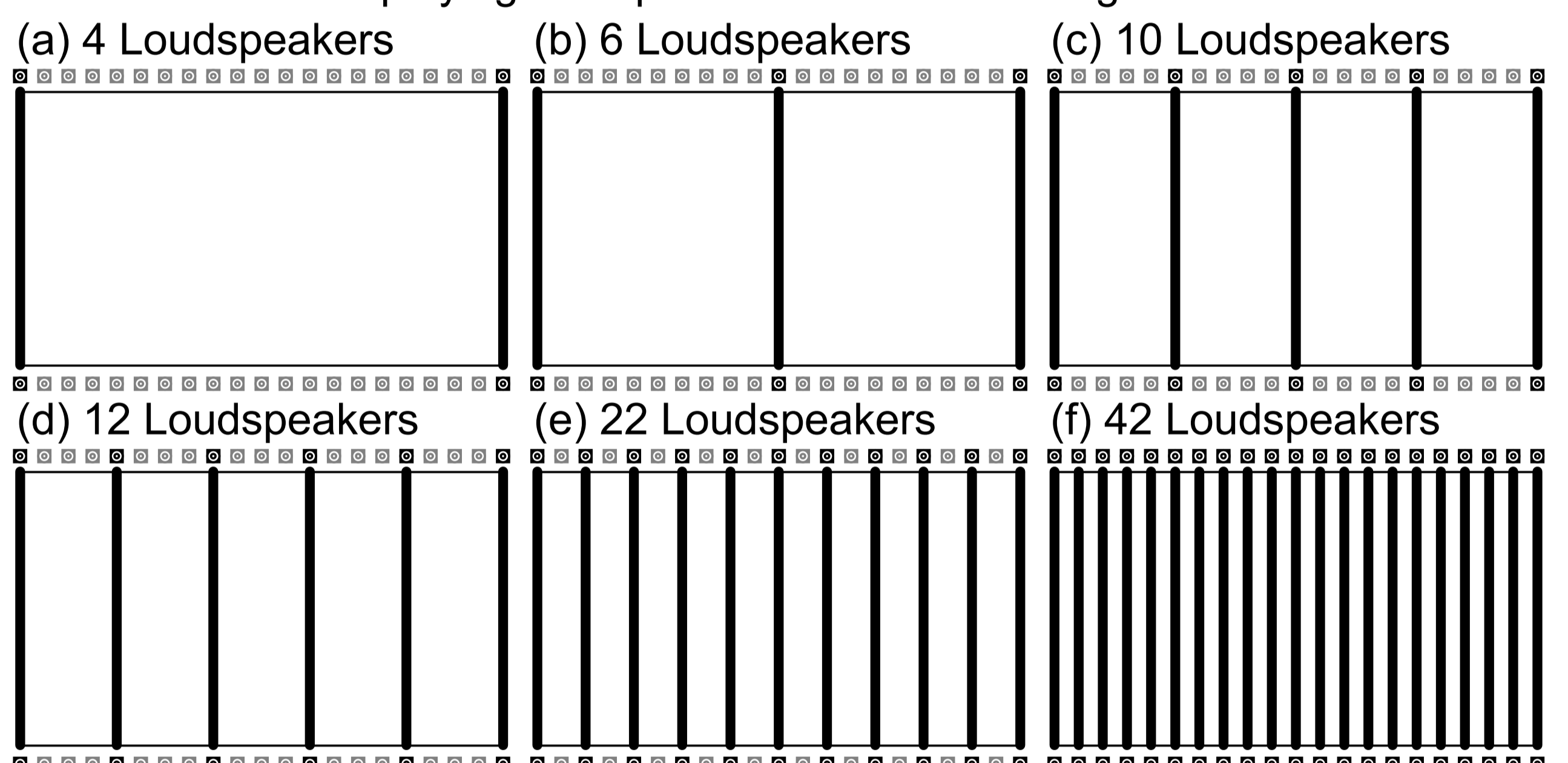

Front View

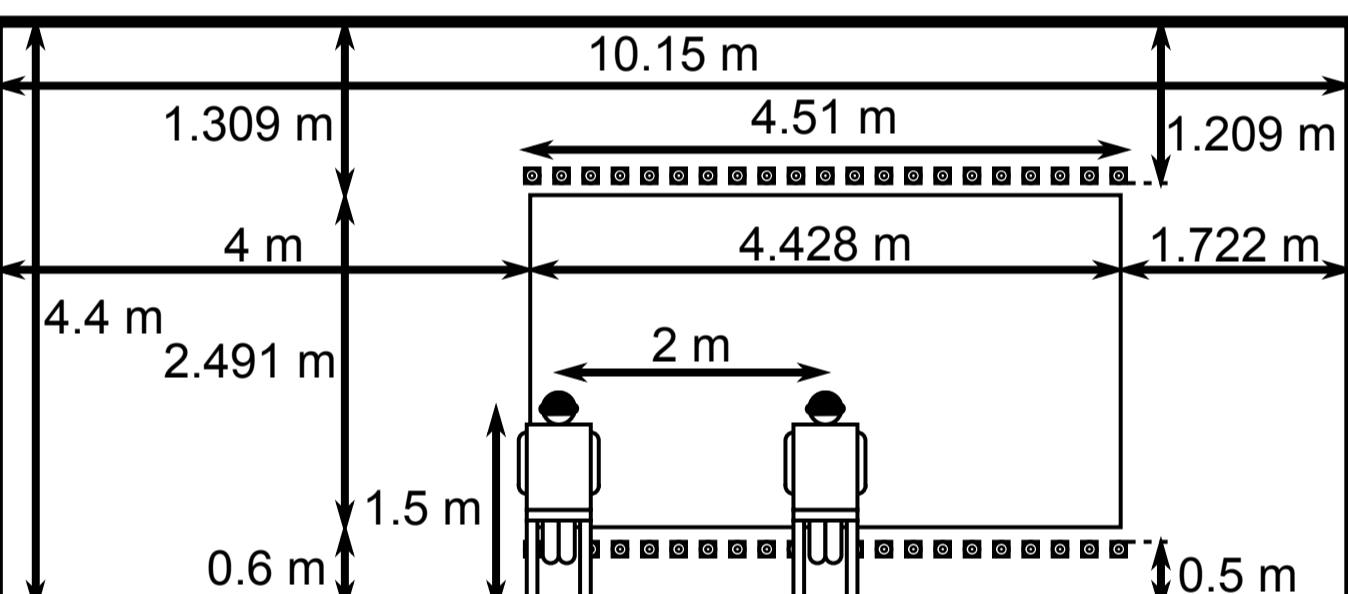

Cross-sectional View

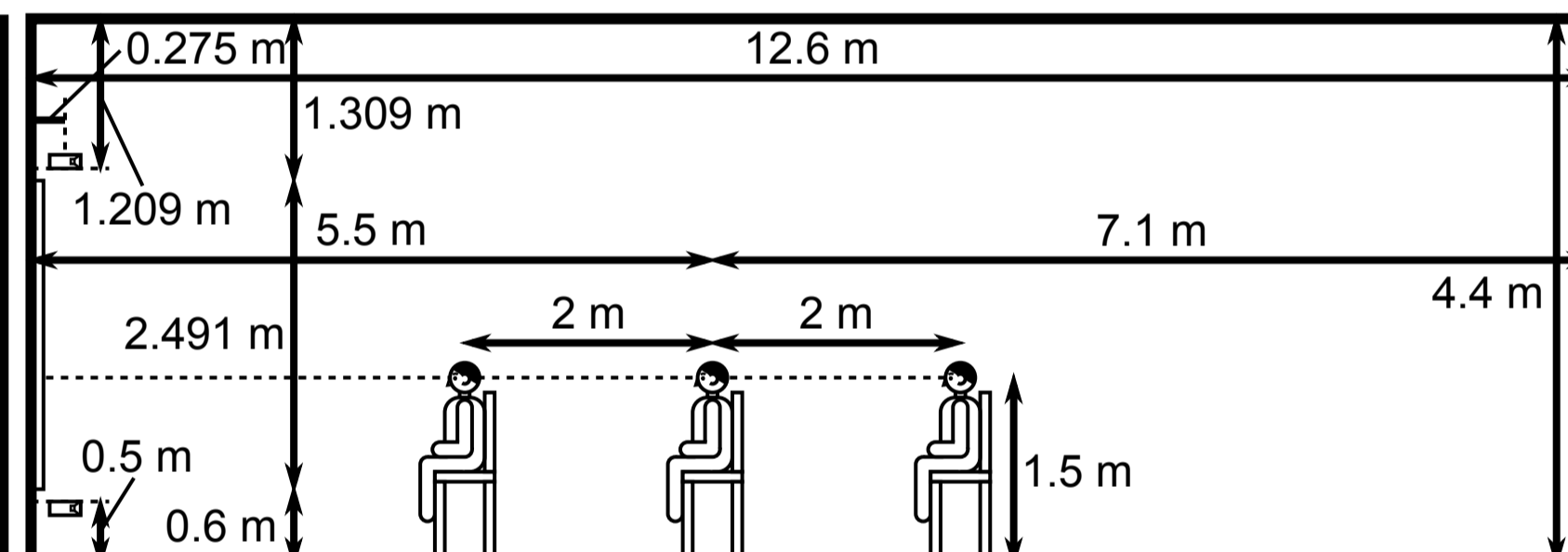

Experimental Design

- Viewer
- + 9 persons
- + 5 males
- + 4 females
- + Age: 29-39
- + Stereoscopic view: Possible
- + Audibility: Normal in daily life
- Method
- + Scheffe's paired comparison

- Evaluation criterion
- + The degree of coincidence
- + Sound location of stars and balls
- + Sound movement of UFO

- Trial
- + Order is randomized in each session

| | Element | Note |
|--------------|-----------------------------|--------------------------|
| Practice (6) | Permutation of 3 conditions | Condition (a), (b) & (f) |
| Main (30) | Permutation of 6 conditions | Condition (a)-(f) |

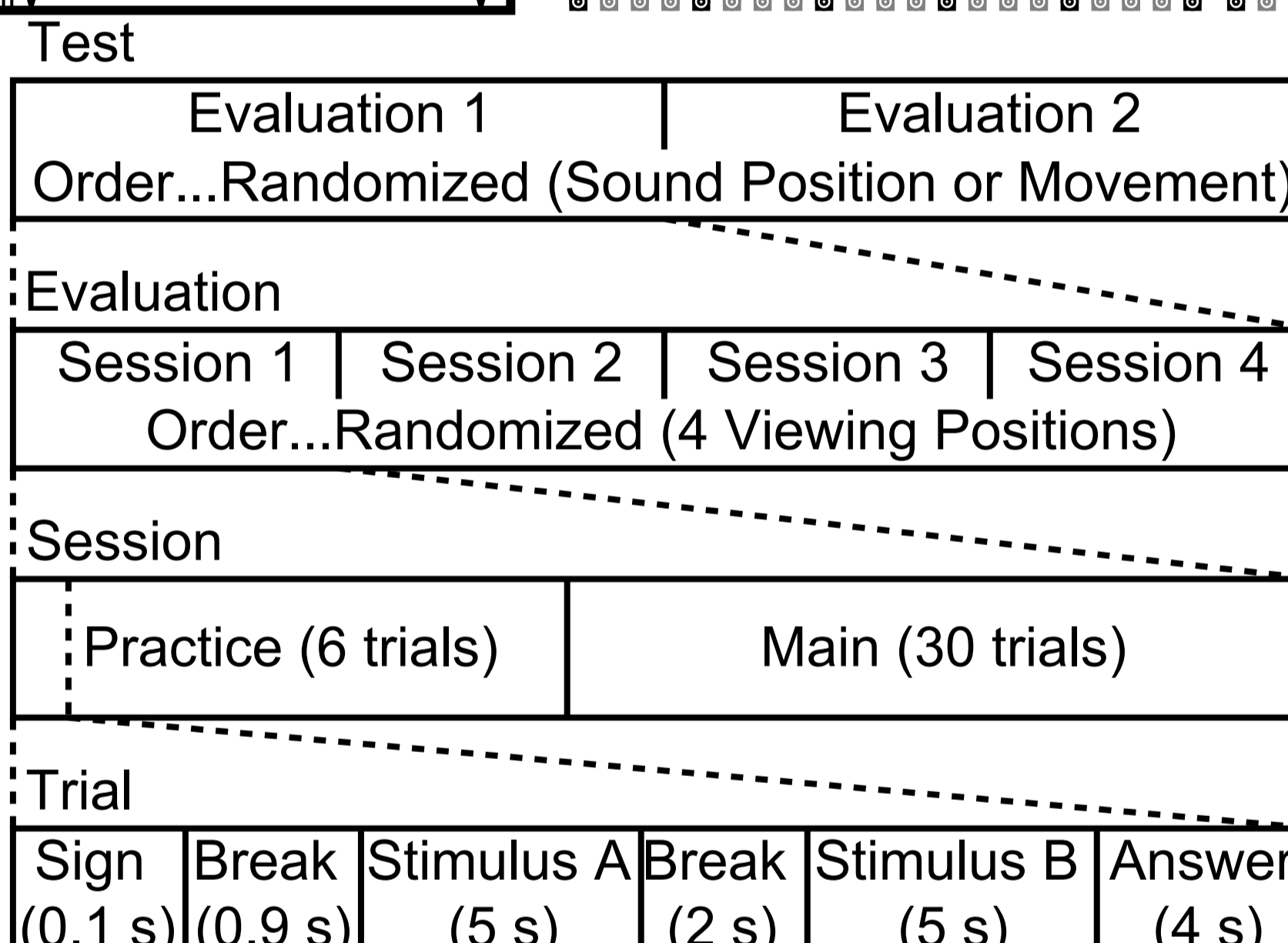

Experimental Procedure

- Instruction
- + Grade the degree of the coincidence of stimulus B
- + Reference: Stimulus A
- + Grade index: 7 steps
- + Be allowed to move their head and upper body freely while listening to a sound

| Grade | Judgment |
|-------|-------------|
| 3 | Very good |
| 2 | Fairly good |
| 1 | Little good |
| 0 | The same |
| -1 | Little bad |
| -2 | Fairly bad |
| -3 | Very bad |

Experimental Results

- 4 or 6 loudspeakers
- + Sometimes the average grades are significantly lower than the basic sound condition (5% level)
- + Basic sound condition: The highest average grade
- 10, 12, 22 or 42 loudspeakers
- + There are no significant differences among basic sound condition

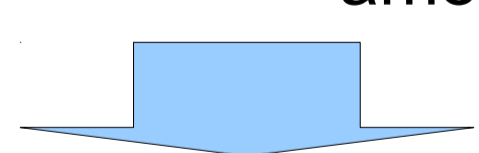

When the number of loudspeakers equals or exceeds ten, viewers cannot discriminate the differences of the location and the movement of sound images even with more loudspeakers

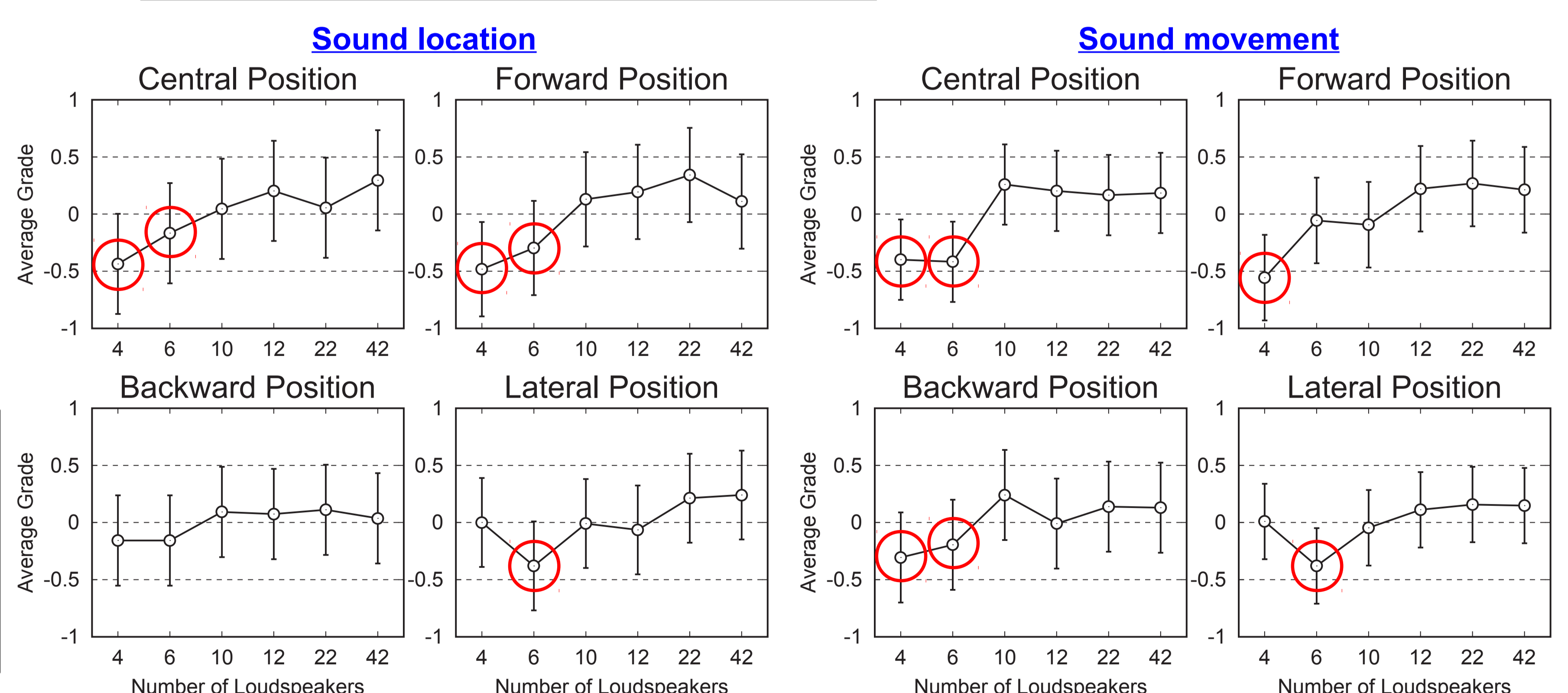

3. CONCLUSION

- Audio-visual experiment was performed to reduce the required number of loudspeakers in our proposed 3D audio system
- + 3D audio system based on multiple vertical panning (MVP)
- Viewers could not discriminate the difference of the sense of presence with ten or more loudspeakers
- + The number of loudspeakers can be reduced to ten when an audio-visual system is based on our proposed system
- Future work: Feasibility of a practical realization of our proposed system
- + Evaluation of the effect of discretization of the vertical position of sound sources
- + Development of the microphone array for recording